

DEVELOPMENT OF COMPREHENSIVE TESTING PROCEDURES FOR HIGH-PERFORMANCE BONDED-IN RODS

Robert Jockwer ¹, Pedro Palma ², Arthur S. Rebouças ³, Alexander Salenikovich ⁴

ABSTRACT: Bonded- or glued-in rods are a highly efficient fastening technology. The complexity of the interaction of different materials in the joint (adhesive, rod, and wood) and non-linear stress distribution along the bondline present special challenges for the precise characterisation of the strength and stiffness properties relevant for the design. The existing test standards and protocols specify only the bare minimum for the utilisation of these connections. The following aspects need a more detailed consideration in test specifications: rods in different wood-based products; impact of spacing and end/edge distances; group effects; quality assurance; fatigue; impact of environmental conditions, fire resistance, etc. In the paper, a detailed state-of-the-art regarding testing of bonded-in rods is given and the different aspects with need for further test development are discussed. Proposals are also made on how to better characterize experimentally the properties and behaviour bonded-in rods and on how to fully utilize their potential in design.

KEYWORDS: glued-in rods, bonded-in rods, combined loading, fatigue, group effects, spacing, end/edge distances, RILEM TC TPT

1 INTRODUCTION

Bonded-in or glued-in rods are highly performant fastening technologies, especially when used to transfer axial forces or moments by means of metal or FRP rods into wood members. If properly designed and produced, they can achieve a very high stiffness, load-carrying capacity, fire resistance and be aesthetically pleasing and cost effective. However, due to the complex interaction of the rod, adhesive, and wood, a reliable characterisation of the properties of the bonded-in rods is particularly challenging and consequently, so is the design.

2 STATE OF THE ART

2.1 Development

The development and utilization of bonded-in rods started in the 1970s. Early developments of bonded-in rods can be traced back to the need to introduce high forces into wood members, especially in the direction parallel to the grain [1]-[3], as well as for reinforcements of existing structures, restoration and renovation [4]&[5]. Through the pioneering work of Turkovsky [6]&[7], joints with inclined bonded-in rods have been successfully used in large-span and outdoor timber structures in the USSR and then in Russia since the 1980s [8] (Figure 1). Major advancements in testing and design of bonded-in rods were achieved in the GIROD project [9]&[10]. In recent years, special systems of bonded-in rods have been developed, favouring a ductile failure in the rod to protect the joints from brittle failures [11]&[12]. Otero-Chans et

al. [14] divided potential improvements of bonded-in rod systems into four groups: (1) hooped systems, (2) hybrid joints, (3) modified rod shapes and (4) modifications in the shape of the drilled hole (Figure 2).

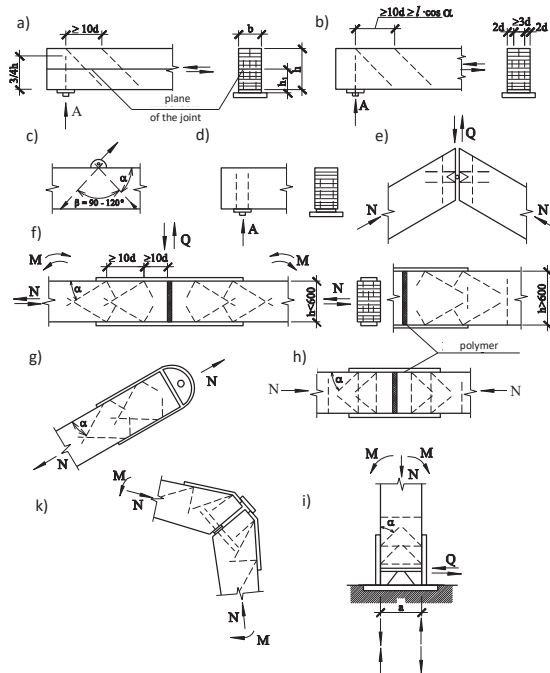

Figure 1: Applications of inclined glued-in rods.[13]

¹ Robert Jockwer, Chalmers University of Technology, Gothenburg, Sweden, robert.jockwer@chalmers.se

² Pedro Palma, Empa, Structural Engineering Research Lab, Switzerland, pedro.palma@empa.ch

³ Arthur S. Rebouças, Federal Institute of Education, Science and Technology of Rio Grande do Norte (IFRN), Brazil arthur.reboucas@ifrn.edu.br

⁴ Alexander Salenikovich, Laval University, Québec, Canada, alsal10@ulaval.ca

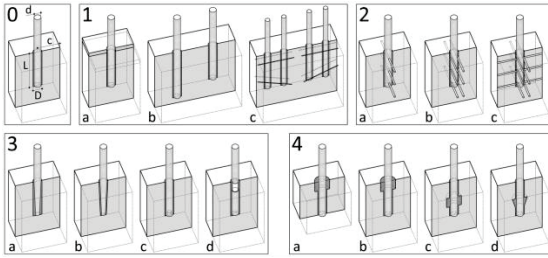

Figure 2: Potential improvements of bonded-in systems. [14]

2.2 Structural behaviour of bonded-in rods

Joints with bonded-in rods rely on the interaction between three components – the wood, the rod, and the adhesive – and the performance of the connection depends first and foremost on the adhesive bond between the wood and the rod (Figure 3). Careful planning, design, preparation, execution, and quality control are required to ensure the integrity, resistance, and durability of the bonded-in rod connection during the design working life of the structure.

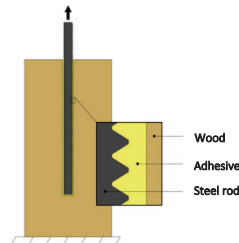

Figure 3: Glued-in rod composite system. [15]

The failure of joints with bonded-in rods can occur in the wood substrate, in the rod, in the adhesive, or at the wood-adhesive or rod-adhesive interfaces. For axially loaded bonded-in rods parallel to the grain, the following failure modes [12]-[16] are considered in the most recent draft of prEN 1995-1-1 Eurocode 5 [17] (Figure 4):

- tensile failure of the rod
- compression (buckling) failure of the rod
- failure of the adhesive within the glue line or in the bondline with the rod and/or timber
- shear failure of the wood adjacent to the bondline
- splitting of the wood starting from the bonded-in rods
- plug shear failure of the wood in a joint with several bonded-in rods
- net tension failure of the wood at the end of the rod.

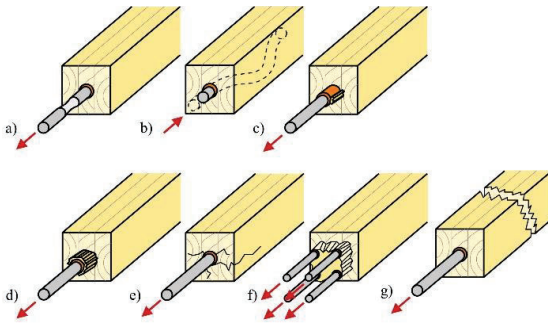

Figure 4: Failure modes of axially loaded bonded-in rods (based on [16]).

For the assessment of the load-carrying capacity and the governing failure modes, the different behavior of the joint components at the various locations must be considered. For example, the wood, the adhesive, and the bondline are characterized by large variability in load-carrying capacity and propensity to brittle failure modes. In contrast, mild-steel rods fail through yielding in a ductile manner and their load-carrying capacity is more predictable, especially if the quality of steel is controlled. Therefore, different partial safety factors are considered for the different failure modes in the design. When the yield failure mode governs the design, the bond strength is underutilized, but it is capacity protected (Figure 5).

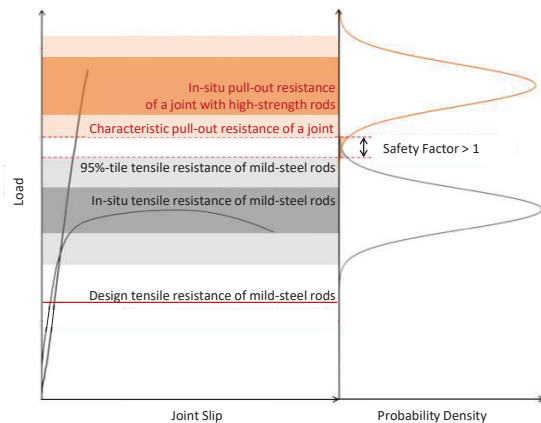

Figure 5: Graphic illustration of the design philosophy of joints with bonded-in rods. [18]

2.3 Standards for testing and design

The complex interaction of the different materials in the joint and the non-linear stress distribution along the bondline present special challenges for the precise characterisation of the strength and stiffness properties relevant for the design.

The testing requirements for bond shear strength of bonded-in rods in glued structural timber products are specified in EN 17334 [19]. Except for the Russian design standard [20], it is the first European test standard for bonded-in rods which sets the basis for the declaration of performance and design. In 2022, ICC-ES published Acceptance Criteria for bonded-in rods used as connections in tension and compression [42].

Several national timber design standards and design guides provide guidance for connections with bonded-in rods [21]-[27] with various degrees of detail. The next generation of prEN 1995-1-1 Eurocode 5 [17], to be published in 2025, will include a chapter on bonded-in rods and will provide general design rules based, amongst other parameters, on the bond strength determined in accordance with EN 17334 [19].

Despite the lack of uniform European or international design guidelines, bonded-in-rods have been successfully applied in a variety of projects across the world. This has allowed further experience to be gained in their use. As a result, various approval documents have been issued for the use of bonded-in rods in timber structures, such as:

- Z-9 1-705 2K-EP-Klebstoff WEVO-Spezialharz [26]
- Z-9.1-896 2K-PUR Klebstoff LOCTITE CR 821 PURBOND [29]
- Z-9 1-778 2K-EP-Klebstoff GSA-Harz [30]
- Z-9.1-791 Studiengemeinschaft Holzleimbau [31]
- Technical Assessment 3/12-716 Soci t  SIMONIN SAS [32]

Recently, European Technical Assessments (ETA) have also been issued for products from various manufacturers [33]&[34] based on EAD 130006-00-0304 [35].

Based on these approvals, available bonded-in rod solutions can be categorized in two main approaches:

- adhesive-based solutions [29]: adhesive manufacturers have developed and certified special adhesives to produce bonded-in rods for specific customers. In the certification documents, the bond strength is specified without specific consideration of the joint configuration.
- system-based solutions [30]&[32]: other manufacturers have achieved approval and certification of proprietary systems of bonded-in rods, considering joints with particular combinations of rods, wood members, and adhesives.

These two approaches allow enough flexibility and specialisation to address the needs of different customers. Adhesive-based solutions require a higher level of detail in the generalized testing and in the description of design procedures to achieve the same desired level of performance in the application, whereas system-based solutions provide exclusive but potentially optimized configurations and range of applications.

In the specifications of the test procedure, EN 17334 [19] focuses primarily on the determination of the bondline shear strength as part of the description of failure mode c) according to the list in Section 2.2. The selection of the dimensions of the timber specimens and steel rods aims at avoiding failure modes comprising yielding of the steel or splitting of the timber members. This means that only some aspects of the bonded-in rod system are considered.

3 SELECTED CHALLENGES IN BONDED-IN ROD TESTING

The main challenges in testing and evaluation of bonded-in rod connections are related to the impact of the material characteristics, connection geometry, load direction and ambient conditions on the load-deformation behaviour, durability, and failure modes. The following selected challenges will be addressed in this paper:

- impact of the adhesive, wood product and grain orientation,
- quality assurance of the bond,
- behaviour in fire,
- stiffness and deformation capacity, and
- multiple rods

3.1 Impact of the adhesive, wood product and grain orientation

The strength of the adhesive bond is limited by the shear strength of the wood, the shear strength of the adhesive, and the bond between them. The shear strength of epoxy adhesives is in the range of 16 to 20 N/mm² [36]. PUR adhesives possess similar strength but are softer and have a lower glass transition temperature [37]. The high strength can only be exploited when rods are used in hardwoods [38]. In softwoods, the adhesive bond strength is generally limited by the shear strength of the wood [39] and the adhesive joint can only be utilized up to a shear strength of about 6 to 8 N/mm².

The bond strength depends on the bondline thickness. It is recognized in EN 17334 [19], which calls for evaluation of bondline thickness from 2 to 6 mm. Furthermore, researchers use larger and/or variable glue line thickness in search of improving the overall performance of the joints [14],[40].

In the case of rods bonded-in parallel to the grain and loaded in axial tension, failure occurs due to an irregular breakout cylinder depending on the local strength of the wood. Therefore, an effective bond strength is used in the design, which must be determined for the individual combination of adhesive, wood and size of the rod or reinforcement type according to EN 17334 [19].

The dependence of the bond strength on the bonded length described in EN 17334 [19] was chosen according to DIN EN 1995-1-1/NA:2013 [21]. Aicher and Stapf [39] discuss various other functions for the reduction of the adhesive bond strength as a function of the bonded length and compare them with test results. In a preliminary draft of EN1995-1-1:2004 *Eurocode 5*, a 10% reduction was proposed for rods bonded-in perpendicular to the grain.

The dependency of the bond strength on the bonded length is based primarily on the studies of bonded-in rods parallel to the grain in softwood glulam. It was observed that in joints with rods bonded-in perpendicular to the grain, the bond strength shows a lower dependency on the bonded length, because wood is much softer in this direction. Therefore, the shear stress distribution is assumed to be constant along the bondline, which cannot be said about the stress distribution along the rods bonded-in and loaded parallel to the grain (Figure 6). For this reason, a constant value can be assumed in design of rods bonded-in perpendicular to the grain within certain limits [40]. In addition, since the bondline failure of rods parallel to the grain can be initiated by the exceedance of failure strain of the wood, the bond strength definition in different wood products and wood species should be determined individually as a function of the angle to the grain. Therefore, the ICC-ES AC526 [42] requires tests of bonded-in rods at various angles to the grain.

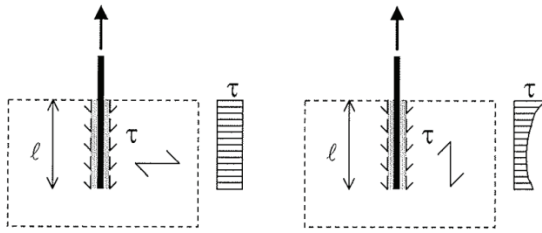

Figure 6: Approximation of the stress distribution by gluing perpendicular and parallel to the grain direction. [40]

To determine the bond strength in accordance with EN 17334 [19], the strength class or yield strength of the steel rod is chosen, depending on the rod diameter and the bond length, to achieve the bond or wood failure without rod yielding. Likewise, AC526 [42] requires that every rod diameter is tested at the maximum, minimum and at least one intermediate bond length using high-strength steel rods that have sufficient strength to develop the bond strength. To determine performance parameters of the joints other than the bond strength, the rods used in the tests should be representative of the class of steel intended for the application.

Bonded-in rods in cross-laminated timber (CLT) are permitted according to the next generation of prEN 1995-1-1 *Eurocode 5* [17]. However, Vallée et al. [43] state that the prediction of the load-carrying capacity of bonded-in rods in CLT is more challenging than in glued-laminated timber due to the increased anisotropy arising from the orthogonal arrangement of the layers. Brittle failure modes of the rods with tear-out of wood blocks from the different layers of the CLT were observed in tests in [44]&[45]. The complex brittle failure modes are influenced amongst others by the rod-to-grain angle, the distances to the cross-layers, spacing between the rods, and also include the rolling shear failure in the interface between the layers.

3.2 Quality assurance of the bond

Bonded-in rods are very demanding in terms of execution, as even minor defects and flaws in production can have a decisive impact on the bond performance. Care must therefore be taken to ensure careful and accurate production and quality assurance.

The effects of various production defects on the load-carrying capacity have been studied in detail [46]. It was found that insufficient grouting and voids along the bondline have the greatest influence on reducing the load-carrying capacity of the joint. Other defects include remaining wood chips in the drilled hole or insufficiently degreased threaded rods.

Gonzalez et al. [47] studied the impact of placing 12.7 mm rods of various lengths off-center during fabrication and did not observe any influence on the resistance nor failure modes. While this may be true for the smaller rods and generous edge distance, for rods of larger diameter and bond length and smaller spacing, the deviation of rod axis off-center may become a reason for splitting of the wood around the rod, which was observed by Salenikovich et al. [48] who tested 16 mm rods in glulam and MPP.

Another serious challenge in bonding of joints is the presence of cavities and gaps between laminations in CLT, where the glue may leak and result in starving joints. The gaps not only increase the consumption of the adhesive dramatically, but the starving joints may also not guarantee the full coverage of the adherends and result in defective bondlines.

One challenge relates to the assurance of the correct curing of the adhesives in the connections. Parameters that can have an impact on the curing of the adhesive are, e.g., the ambient and material temperatures during bonding and curing, the correct mixing ratio, and the moisture content of wood. Errors in the estimates of the wood temperature in cold climates may lead to the reduced pot life of the glue and defective bond.

Compliance withdrawal tests that can be used as an indicator for the correct curing of the adhesive in the bondline of bonded-in rods were developed together with the design and execution guidelines for the next generation of prEN 1995-1-1 *Eurocode 5* [17] and should be included in the next revision of EN1382 [49].

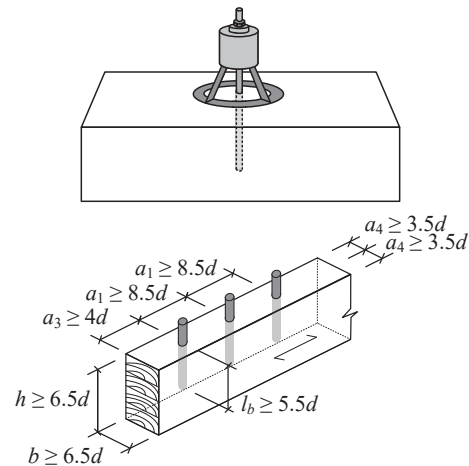

Figure 7: Example of the compliance withdrawal test arrangement and the specimen geometry

Such compliance withdrawal test may be carried out in *pull-beam*, *pull-compression*, or *pull-pile foundation* configurations as illustrated in Figure 7. The rods should be bonded in the direction perpendicular to the grain, to avoid splitting of the timber in the vicinity of the bondline. To avoid premature splitting of the wood member, the spacing and end and edge distances should be sufficiently large and exceed the minimum required values in the design regulations. Since the bond shear test is aimed at the bondline failure, the bonded length may be shorter than the minimum values given in the design standards, and a length of $5.5 \cdot d$ can be proposed for softwood. This test procedure is very similar to the quality assurance tests conducted in accordance with GOST R 56710 [20] except that the rods are pushed through (Figure 8).

3.5 Multiple rods

3.5.1 Situation

During the last 30 years, several studies have been carried out on bonded-in rod connections, mainly focused on the pull-out resistance and on the bond behaviour between the rod and the wood. Most of the literature on the subject was initially focused on investigating the load-slip relationship and defining the failure mechanisms for a single-rod connection.

The few existing design codes with specific guidance for bonded-in rods, such as DIN EN 1995-1-1/NA [21], deal with the definition of the load-carrying capacity of a single rod or provide a simple adjustment to account for the uneven load distribution between the rods [13]. In the most recent draft of prEN 1995-1-1 *Eurocode 5* [17], the chapter on bonded-in rods addresses primarily joints with single rods and is based on bond strength determined in accordance with EN 17334 [19], which is also determined on single rod test specimens.

In practice, bonded-in rods are used in groups and a more detailed knowledge of their structural behaviour is relevant for the research community and designers [67]. That is why AC526 [42] requires testing groups of four rods placed at distances representative of the minimum allowed spacing for the system.

Due to a very high stiffness, bonded-in threaded rods cannot easily ensure redistribution of loads unless the rods start yielding. However, if the yield strength of the rods is higher than the bond strength, then the redistribution may not be possible and an uneven loading in a group of fasteners will lead to a brittle failure of the overloaded rod [65]. That is why the current design philosophy favours the design of joints with bonded-in rods where the yielding of the rods governs.

Unlike single joints, few data are available in the literature for multiple bonded-in rod connections. In general, available studies can be divided into pull-out tests (almost equally loaded tension joint) and moment-resisting connections (unequally loaded joints).

A reduction for the load-carrying capacity due to uneven force distribution is given by Turkovsky [4], based on the USSR standard of 1982. There, the reduction in load-carrying capacity due to uneven load distribution between rods is applied by reducing the load-carrying capacity 10% for two rods and 20% for three rods in a row parallel to the grain. The resistance is further reduced 10% if the bars are arranged in two rows perpendicular to the grain. Buchanan [24] proposed the following reduction of the load-carrying capacity for "closely spaced" rods: the full load-carrying capacity can be used for one or two rods, it must be reduced 10% for three or four rods, and reduced 20% for five or six rods. Based on the above recommendations, in the most recent draft of prEN 1995-1-1 *Eurocode 5* [17], a reduction of 10% is suggested for three to four rods and 20% for five or more rods, unless a uniform load distribution can be assumed. Connections with more than six rods are not recommended without a uniform load distribution.

In moment resisting connections, such as knee joints, with several layers of rods bonded-in parallel to the grain, Buchanan [24] recommended to have staggered bonded lengths by offsetting the rod ends by at least 75 mm to minimize the risk of splitting along the rods and to reduce the stress concentrations at the rod ends (Figure 9). In addition, it is recommended to check the wood fracture at tips of steel rods for the tensile force acting in each layer in such connections [26] (Figure 10).

3.5.2 Multiple rods pull-out tests

Several studies have focused on observing the failure modes, verifying the possibility of achieving ductile failure and evaluating the influence of the main geometric parameters (rod diameter, distance between rods, distance to edges, bonded length) and mechanical properties (yield and ultimate strength of rods) on the structural behaviour of the joints [47]&[68]-[71].

The test setups and procedures used are very similar to that for single rod joints and the loading protocol follows the recommendations given by ISO 6891 [72]. The maximum load, failure mode and displacement at failure are measured. From these tests, the load-carrying capacity of the joint is compared with the pull-out capacity of a single rod and the tensile resistance of the rod, which are usually predicted from analytical formulations. A group reduction factor for connections with multiple rods can be derived from this comparison.

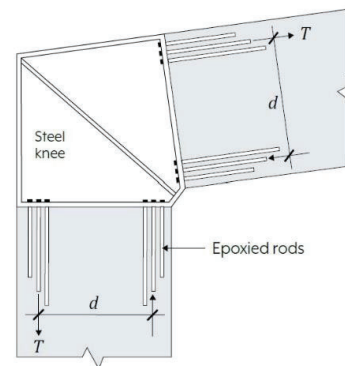

Figure 9: Staggered rod ends in a knee joint. [26]

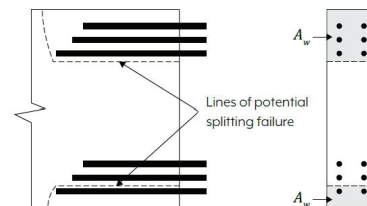

Figure 10: Wood area for checking wood fracture capacity in a knee joint. [26]

In many cases, failures occur due to splitting that starts at the end of the wood member and extends along the length of the rod before the onset of yielding. This could be in part due to the difficulty of fabricating connections with multiple rods that are perfectly aligned. Sometimes, there are defects in the bondline along the length of the rods. To mitigate the splitting failures, it is possible to reinforce the

wood member using perpendicular fasteners such as screws or smaller bonded-in rods. In fact, in Russia, the use of bonded-in rods parallel to the grain is not recommended, and transverse reinforcement is required in all connections [13].

In connections with multiple bonded-in rods, it is often aimed at small edge distances to increase the overall efficiency of the connection (i.e., less than $2.5 \cdot d$, which is the minimum distance recommended by most current standards to avoid splitting). When testing the bondline strength according to EN 17334 [19] larger edge and end distances of single rods are used. Gonzalez et al. [47] suggested a minimum edge distance of $3 \cdot d$ to avoid splitting and a minimum spacing of $5 \cdot d$ between rods to prevent splitting. When smaller spacings are used, special measures can be taken to minimize the risk of splitting, such as the use of a not-bonded length towards the end of the timber member. In the current test standard EN 17334 [19], such special measures are not specifically addressed. However, to evaluate the full performance of bonded-in rod system, the bond strength must be tested in combination with the specific measures to reduce the risk of splitting. That is why the not-bonded length and other features may be tested under AC526 [42].

The impact of the rod ductility and redistribution of load was evaluated by Gehri [73] and by Bouchard et al. [65] for connections loaded in axial tension. Larger test series on connections with multiple rods were described by Parida et al. [68], where the influence of low and high steel quality on the failure mode, capacity and ductility were investigated. Steiger et al. [74] stated that the use of "mild steel as well as more bars of smaller diameter are effective measures to increase the ductility of the connection." Especially for connections with several rods where unequal loading in the rods is expected, a high ductility of the joint is required to allow balancing and redistribution of the load.

It can be concluded that not only a single bonded-in rod joint, but the entire connection should be tested and that the system behaviour of the bonded-in rods should be considered. For pull-out tests, it is important to keep an even distribution of stresses across the section so that all rods are equally loaded. This can be achieved using a rigid plate at the end of the rods, fixing them with an extra length so that the rods could deform. However, it is not necessarily representative of the real joint configuration. In general, mild-steel rods are recommended for testing connections with multiple bonded-in rods, as well as in design, to facilitate the yielding and redistribution of loads between rods before other failure modes occur or any imperfections during production of the connection may result in much lower capacity than expected (see Fig.4).

4 PROPOSALS

The complexity of bonded-in rod connections as a system requires further development of tests methods, procedures, and protocols. Some of the most relevant aspects are:

- Rods in different wood-based products. The current European standard test procedures are based on rods bonded parallel to the grain in glued laminated timber or in CLT. The bond strength of rods bonded perpendicular to the grain is assumed to be equivalent. The impact of cross-layers in CLT and veneers in LVL and other wood-based products should be evaluated, especially regarding layer thickness and distribution, edge distances and potential edge intersection with the rod. The literature review revealed the occurrence of undesirable failure modes, including rolling shear of the cross-layers, depending on the specimen configuration.
- Quality assurance of the bond. The quality of the bondline must be verified to ensure the intended performance of the bonded-in rods. Quality assurance testing on representative specimens prepared in parallel to the production of the actual bonded-in rod joints, like it is done in Russia [20], can be a way to verify the correct curing of the adhesive in the bondline under the same environmental conditions and materials. In addition, it would be desirable to perform non-destructive tests to assess the integrity of the bondline after curing (e.g., proof-loading, X-ray scanning).
- Behaviour in fire. The bonded length of the rods is protected by the wood, but different adhesive systems show different sensitivity to high temperatures. The rod end is often exposed and connected to other metallic components that can act as a heat bridge into the connection and bondline. Gaps between connected members also influence the fire performance. The exact configuration of the system and not fully protected rods should be experimentally evaluated.
- Testing groups of rods. Bonded-in rods are most often used in groups, either acting all together with almost equal loading (such as in a tension joint) or with unequal loading (such as in a moment-resisting joint). In both cases, group effects, i.e., reduced load-carrying capacity of the group of rods compared to the sum of the individual rod capacities, may be observed. This aspect should be considered in the testing of the bonded-in rods in a system. Procedures developed in AC526 [42] can be taken as a starting point.
- Rod spacing and improved systems. So far, only tests on single rods with relatively large edge distances have been standardized in Europe for the determination of the bond strength. According to the proposal in the most recent draft of prEN 1995-1-1 *Eurocode 5* [17], the minimum spacing and edge distances must be chosen depending on the bond strength assumed in the design. Hence, to account for a higher bond strength, a larger spacing, a recess (not-bonded length), or any other potential improvements can be required for qualification testing. However, specific spacing requirements for different wood-based products, particularly for hardwoods and LVL, are missing. Procedures developed in AC526 [42] can be taken as a starting point.

- Fatigue behaviour. Bonded-in rods are often applied in conditions prone to fatigue loading. Depending on the configuration, the fatigue strength is typically governed by properties of the rods. However, the fatigue strength of the adhesive bond or wood may also govern. To reliably predict the performance of the connection, the exact configuration of the system should be evaluated.
- Impact of temperature and moisture conditions. The environmental conditions during curing of the adhesive and in the final application have an impact on the performance of the connection. More practical test procedures must be developed to quantify these effects. AC526 [42] may be used as an example.

5 CONCLUSIONS

A review of the state-of-the-art regarding testing of bonded-in rods is given and the different aspects that need for further development of test specifications are discussed.

Proposals are made on how to better characterize the properties and behaviour of groups of bonded-in rods in tests and how to fully utilize their potential in design.

ACKNOWLEDGEMENT

The paper is based on the work of the working group on bonded-in rods in RILEM TC TPT “Tests methods for a reliable characterization of resistance, stiffness and deformation properties of timber joints”.

REFERENCES

- [1] A. Baumeister, H. Blumer, H. Brüninghoff, J. Ehlbeck, B. Koehlen, P. Köster, G. Maier, K.-H. Meyer, D. Steinmetz, and J. Wenz. 1972. Neuere Karlsruher Forschungsarbeiten und Versuche im Ingenieurholzbau. *Bauen mit Holz* 74, 6 (1972), 298–317.
- [2] G. Edlund. 1975. In *Brettschichtholz eingeleimte Gewindestangen*. Svenska Träforskningsinstitutet, Med. Serie B 33 (1975).
- [3] H. Riberholt. 1979. *Eingeleimte Gewindestangen*. Danmarks Tekniske Højskole, Afdelingen for Baerende Konstruktioner, Lyngby, Denmark.
- [4] Klapwijk, D. 1878. Restoration and preservation of decayed timber structures and constructions with epoxies. Preprints of the contribution to the Oxford Congress, London, UK, pp.75-76.
- [5] Taupon, J. 1980. Restauration à la résine époxyde de planchers et charpentes au Monastère de la Grande Chartreuse. *Bulletin d'Informations Techniques* 92, 34-43.
- [6] S. Turkovsky. 1989. Designing of glued wood structures joints on glued-in bars. Paper 22-7-13, In Proc. of the CIB-W18 Meeting 22, Berlin, Germany.
- [7] Turkowskij, S. 1991. “Prefabricated Joints of Timber Structures on Inclined Glued-in Bars.” In Proceedings of the 1991 International Timber Engineering Conference, TRADA, London, UK.
- [8] С. Б. Турковский, А. А. Погорельцев, И. П. Преображенская. Клеенные деревянные конструкции с узлами на клеенных стержнях в современном строительстве (система ЦНИИСК). Москва, РИФ «Стройматериалы». 2013. (in Russian)
- [9] TRADA. (2001). “GIROD -Glued-in Rods for Timber Structures WP 8 -Draft Design Rules for Eurocode 5 - 36th Month Progress Report.” UK.
- [10] Bengtsson, C., and C.-J. Johansson. (2002). GIROD-Glued in Rods for Timber Structures. SMT4-CT97-2199.
- [11] Steiger, R., E. Gehri, and R. Widmann. (2007). “Pull-out Strength of Axially Loaded Steel Rods Bonded in Glulam Parallel to the Grain.” *Materials and Structures/Materiaux et Constructions* 40 (1): 69–78.
- [12] R. Steiger. 2012. In *Brettschichtholz eingeklebte Gewindestangen – Stand des Wissens zu einer leistungsfähigen Verbindungstechnik*. In Proc. of the Internationales Holzbau-Forum, Garmisch-Partenkirchen, Germany.
- [13] CP382. Glued laminated timber structures with glued-in rods. Design methods. Moscow, RF, 2018.
- [14] D. Otero-Chans, J. Estévez-Cimadevila, E. Martín-Gutiérrez, F. Suárez-Riestra. 2019. Systems that improve the behaviour of joints made using glued-in rods. *European Journal of Wood and Wood Products*. 77:1079–1093 <https://doi.org/10.1007/s00107-019-01461-4>
- [15] R. Bouchard. 2021. Comportement en traction longitudinale d'assemblages multi-tiges encollées dans le bois lamellé-collé. Mémoire M. Sc. Université Laval. <http://hdl.handle.net/20.500.11794/69035>
- [16] G. Tlustochowicz, E. Serrano, and R. Steiger. 2011. State-of-the-art review on timber connections with glued-in steel rods. *Materials and Structures/Materiaux et Constructions* 44, 5 (2011), 997–1020.
- [17] prEN 1995-1-1: Eurocode 5 Design of timber structures — Part 1-1: General rules and rules for buildings. CEN/TC 250/SC 5 N 1650, CEN European committee for standardization, Brussels, Belgium, 12-2022.
- [18] A. Salenikovich, R. Bouchard, C. Frenette, G. Bédard-Blanchet. A study of the tensile behaviour of joints with multiple glued-in steel rods in glued-laminated timber. In: *Proceedings of WCTE 2021*, Santiago, Chile. 2021.
- [19] EN 17334 - Glued-in-Rods in Glued Structural Timber Products — Testing, Requirements and Bond Shear Strength Classification. European Committee for Standardization CEN, Brussels, Belgium, 2021.
- [20] ГОСТ Р 56710-2015. Соединения на клеенных стержнях для деревянных конструкций. Технические условия. Москва. Стандартинформ. 2016. (in Russian)
- [21] DIN EN 1995-1-1/NA: National Annex - Nationally Determined Parameters - Eurocode 5: Design of Timber Structures - Part 1-1: General - Common Rules and Rules for Buildings. Berlin, Germany: DIN Deutsche Institut für Normung e.V., 2013.

- [22] SIA. 2021. Norm SIA 265:2021 - Holzbau. SIA - Schweizerischer Ingenieur- und Architektenverein: Zürich, Switzerland.
- [23] CNR. 2007. CNR-DT 206-2007, Istruzioni per la Progettazione, l'Esecuzione ed il Controllo delle Strutture di Legno. Consiglio Nazionale delle Ricerche, CNR, Commissione di studio per la predisposizione e l'analisi di norme tecniche relative alle costruzioni.
- [24] A. Buchanan. 2007. NZW 14085 SC, New Zealand Timber Design Guide. Timber Industry Federation Inc., Wellington, New Zealand.
- [25] Svenskt Trä. 2016. Limträhandbok, Projektering av limträkonstruktioner, Del 2. Svenskt Trä, Föreningen Sveriges Skogsindustrier, Stockholm, Sweden.
- [26] WMPA. Portal knee connections. NZ Wood Design Guide. Chapter 12.5. April 2020.
- [27] D. Moroder. Design of glued-in rods or bars. 2020. New Zealand Timber Design Journal. Vol. 28, issue 3:26-31.
- [28] DiBt. Z-9.1-705 2K-EP-Klebstoff WEVO-Spezialharz EP 32 S mit WEVO-Härter B 22 TS zum Einkleben von Stahlstäben in Holzbaustoffe, WEVO-CHEMIE GmbH. Deutsches Institut für Bautechnik, Berlin, Germany, 2021.
- [29] DiBt. "Z-9.1-896 2K-PUR Klebstoff LOCTITE CR 821 PURBOND Zum Einkleben von Stahlstäben in Tragende Holzbauteile, Henkel & Cie. AG." Berlin, Germany: Deutsches Institut für Bautechnik, Berlin, Germany, 2020.
- [30] DiBt. "Z-9.1-778 2K-EP-Klebstoff GSA-Harz Und GSA-Härter Für Das Einkleben von Stahlstäben in Holzbaustoffe, Neue Holzbau AG." Berlin, Germany: Deutsches Institut für Bautechnik, Berlin, Germany, 2017.
- [31] DiBt. Z-9.1-791 Verbindungen mit faserparallel in Brettschichtholz eingeklebten Gewindestangen für den Holzbau, Studiengemeinschaft Holzleimbau e. V. Deutsches Institut für Bautechnik, Berlin, Germany, 2021.
- [32] CSTB. Avis Technique 3.3/19-986. Assemblage pour structure bois. Goujons collés RBF. Titulaires: Société SIMONIN SAS, Société JPF-DUCRET SA. Champs-sur-Marne, France, 2019.
- [33] OIB. "ETAssessment 19/0752 - GSA® - Technologie, Glued-in Rods for Timber Connections." EAD 130006-00-0304. Vienna, Austria: OIB Austrian Institute of Construction Engineering, 2020.
- [34] OIB. "ETAssessment 20/0834 - Hilti HIT-RE 500 V4, Timber Structures - Glued-in Rods for Timber Connexions." EAD 130006-00-0304. Vienna, Austria: OIB Austrian Institute of Construction Engineering, 2020.
- [35] EOTA. "EAD 130006-00-0304 - Glued-in Rods for Timber Connections." Pending for Citation in OJEU. Brussels, Belgium: EOTA - European Organisation for Technical Assessment.
- [36] E. Gehri. 1995. Krafteinleitungen mittels Stahlanker. In Brettschichtholz - Material, Bemessung, Ausführung, Qualitätssicherung, Weinfelden, Switzerland.
- [37] M. Verdet. 2017. Étude du comportement à long terme de systèmes d'assemblages par goujons collés en conditions climatiques variables. Thèse PhD. Université Laval. <http://hdl.handle.net/20.500.11794/27530>
- [38] O. Bletz-Mühldorfer, L. Bathon, D Grundwald, T. Vallee, S. Myslicki, and F. Walther. 2017. Eingeklebte Stäbe in Laubholzkonstruktionen. Bauen mit Holz 4 (2017), 34–39.
- [39] S. Aicher and G. Stapf. 2017. Eingeklebte Stahlstäbe - state-of-the-art - Einflussparameter, Versuchsergebnisse, Zulassungen, Klebstoffnormung, Bemessungs- und Ausführungsregeln. In Internationales Holzbau-Forum (IHF 2017), Garmisch-Partenkirchen, Germany.
- [40] Schober, K., and T. Tannert. 2016. "Hybrid Connections for Timber Structures." European Journal of Wood and Wood Products 74, no. 3: 369–77. <https://doi.org/10.1007/s00107-016-1024-3>.
- [41] A. Bernasconi. 2001. Behaviour of axially loaded glued-in rods – requirements and resistance, especially for spruce timber perpendicular to the grain direction. Paper 34-7-6. CIB-W18 Meeting 34, Venice, Italy.
- [42] ICC-ES AC526. Acceptance criteria for factory installed glued-in rods in wood structural elements. 2022.
- [43] Vallée, Till, Hossahalli Ramesh Rakesh, and Thomas Tannert. "Load-Carrying Capacity Prediction of Single Rods Glued into Cross-Laminated Timber." European Journal of Wood and Wood Products 80, no. 5 (October 1, 2022): 1041–55. <https://doi.org/10.1007/s00107-022-01835-1>.
- [44] Azinović, Boris, Erik Serrano, Miha Kramar, and Tomaž Pazlar. "Experimental Investigation of the Axial Strength of Glued-in Rods in Cross Laminated Timber." Materials and Structures 51, no. 6 (October 18, 2018): 143. <https://doi.org/10.1617/s11527-018-1268-y>.
- [45] Ayansola, G.S., T. Tannert, and T. Vallee. "Glued-in Multiple Steel Rod Connections in Cross-Laminated Timber." Journal of Adhesion 98, no. 6 (2022): 810–26. <https://doi.org/10.1080/00218464.2021.1962715>.
- [46] N. Ratsch, S. Böhm, M. Voß, M. Kaufmann, and T. Vallée. 2019. Influence of imperfections on the load capacity and stiffness of glued-in rod connections. Construction and Building Materials 226, (November 2019), 200–211. DOI: <https://doi.org/10.1016/j.conbuildmat.2019.07.278>
- [47] E. Gonzales, T. Tannert, T. Vallee, The impact of defects on the capacity of timber joints with glued-in rods, Int. J. Adhesion & Adhesives 65 (2016) 33–40 DOI: <https://doi.org/10.1016/j.ijadhadh.2015.11.002>
- [48] A. Salenikovich, É. Lapointe, B. Zumbrunn-Maurer, T. Brotschi, A. Kramer. Performance of glued-in rods in glulam and MPP in tension and compression. In: *Proceedings of WCTE 2023*, Oslo, Norway. 2023.
- [49] EN 1382: 2016. Timber structures - Test methods - Withdrawal capacity of timber fasteners. CEN European committee for standardization, Brussels, Belgium, 2016.

- [50] ISO 2859-1:1999/Cor 1:2001. Sampling procedures for inspection by attributes — Part 1: Sampling schemes indexed by acceptance quality limit (AQL) for lot-by-lot inspection.
- [51] P. Palma, A. Frangi, E. Hugi, P. Cachim, H. Cruz, Fire resistance tests on steel-to-timber dowelled connections reinforced with self-drilling screws, in: Proc. 2nd Ibero-Lat.-Am. Congr. Fire Saf. – 2nd CILASCI, Coimbra, Portugal, 2013: p. 11.
- [52] P. Palma, A. Frangi, E. Hugi, P. Cachim, H. Cruz, Fire resistance tests on timber beam-to-column shear connections, *J. Struct. Fire Eng.* 7 (2016) 41–57. <https://doi.org/10.1108/JSFE-03-2016-004>.
- [53] P. Palma, Fire behaviour of timber connections, Doctoral thesis, ETH Zürich, 2016.
- [54] EN 1995-1-2:2004. Eurocode 5: Design of timber structures – Part 1-1: General – Structural fire design, European Committee for Standardization (CEN), Brussels, 2004.
- [55] S. Harris, Fire resistance of epoxy-grouted steel rod connections in laminated veneer lumber (LVL), MS, University of Canterbury, 2004. http://www.civil.canterbury.ac.nz/fire/pdfreports/S_Harris04.pdf.
- [56] S. Harris, W. Lane, A. Buchanan, P. Moss, Fire performance of laminated veneer lumber (LVL) with glued-in steel rod connections, in: Struct. Fire - Proc. Third Int. Workshop, Ottawa, Canada, 2004: pp. 411–424. <http://www.structuresinfire.com/corpo/conferences/sif04.pdf>.
- [57] L. Luo, B. Shi, W. Liu, H. Yang, Z. Ling, Experimental investigation on the fire resistance of glued-in rod timber joints with heat resistant modified epoxy resin, *Materials*. 13 (2020) 2731. <https://doi.org/10.3390/ma13122731>.
- [58] T. Oksanen, J. Kangas, Strength and fire resistance of connections based on glued-in rods, VTT Technical Research Centre of Finland, Espoo, 1999.
- [59] EN-1363-1:2020. Fire resistance tests – Part 1: General requirements. CEN European committee for standardization, Brussels, Belgium, 2020.
- [60] E. Gonzalez, C. Avez, and T. Tannert. 2016. Timber joints with multiple glued-in steel rods. *The Journal of Adhesion*, 92, 7–9 (2016), 635–651.
- [61] F. Hunger, M. Stepinac, V. Rajčić, and J.-W. van de Kuilen. 2016. Pull-compression tests on glued-in metric thread rods parallel to grain in glulam and laminated veneer lumber of different timber species. *European Journal of Wood and Wood Products* 74, 3 (2016), 379–391.
- [62] J. Ogrizovic, R. Jockwer, and A. Frangi. 2018. Seismic Response of Connections with Glued-in Steel Rods. In Proc. of the INTER Meeting 5/Paper 51-7-5, Tallinn, Estonia.
- [63] M. del Senno, M. Piazza, and R. Tomasi. 2004. Axial glued-in steel timber joints—experimental and numerical analysis. *Holz Roh Werkst* 62, 2 (April 2004), 137–146. DOI: <https://doi.org/10.1007/s00107-003-0450-1>
- [64] M. Verdet, A. Salenikovich, A. Cointe, J.-L. Coureau, P. Galimard, W. Munoz Toro, P. Blanchet, and C. Delisée. 2016. Mechanical Performance of Polyurethane and Epoxy Adhesives in Connections with Glued-in Rods at Elevated Temperatures. *BioResources* 11, 4 (August 2016), 8200–8214
- [65] R. Bouchard, A. Salenikovich, C. Frenette, and G. Bedard-Blanchet. 2021. Experimental investigation of joints with multiple glued-in rods in glued-laminated timber under axial tensile loading. *Construction and Building Materials* 293, (July 2021), 122614. DOI: <https://doi.org/10.1016/j.conbuildmat.2021.122614>
- [66] H.J. Blaß and Y. Steige. 2018. Steifigkeit axial beanspruchter Vollgewindeschrauben. DOI: <https://doi.org/10.5445/KSP/1000085040>
- [67] Stepinac M, Hunger F, Tomasi R, Serrano E, Rajcic V, van de Kuilen JW. Comparison of design rules for glued-in rods and design rule proposal for implementation in European standards. In: Rainer Görlacher, editor. Proceedings of CIB-W18 Meeting 46, Vancouver, Canada; 26–29 August 2013.
- [68] G. Parida, H. Johnsson, and M. Fragiaco. 2013. Provisions for Ductile Behavior of Timber-to-Steel Connections with Multiple Glued-In Rods. *J. Struct. Eng.* 139, 9 (2013), 1468–1477. DOI: [https://doi.org/10.1061/\(ASCE\)ST.1943-541X.0000735](https://doi.org/10.1061/(ASCE)ST.1943-541X.0000735)
- [69] Gehri E. Ductile behaviour and group effect of glued-in steel rods. Joints in Timber Structures. In: International RILEM symposium, Stuttgart, Germany; 2001. p. 333–42.
- [70] Broughton JG, Hutchinson AR. Pull out behaviour of steel rods bonded into timber. *Mater Struct* 2001;34–2:100–9.
- [71] Gattesco N, Gubana A, Buttazzi M. Pull out strength of bar glued-in-joints. In: Proc. of the 11th world conference on timber engineering, Riva del Garda, Italy; 2010.
- [72] ISO 6891:1983. Timber structures — Joints made with mechanical fasteners — General principles for the determination of strength and deformation characteristics. Reapproved in 2021.
- [73] E. Gehri. 2016. Performant connections - A must for veneer-based products. In Proc. of the World conference on timber engineering WCTE, Vienna, Austria.
- [74] R. Steiger, E. Serrano, M. Stepinac, V. Rajčić, C. O'Neill, D. McPolin, and R. Widmann. 2015. Strengthening of timber structures with glued-in rods. *Construction and Building Materials* 97, (October 2015), 90–105. DOI: <https://doi.org/10.1016/j.conbuildmat.2015.03.097>